

czzl

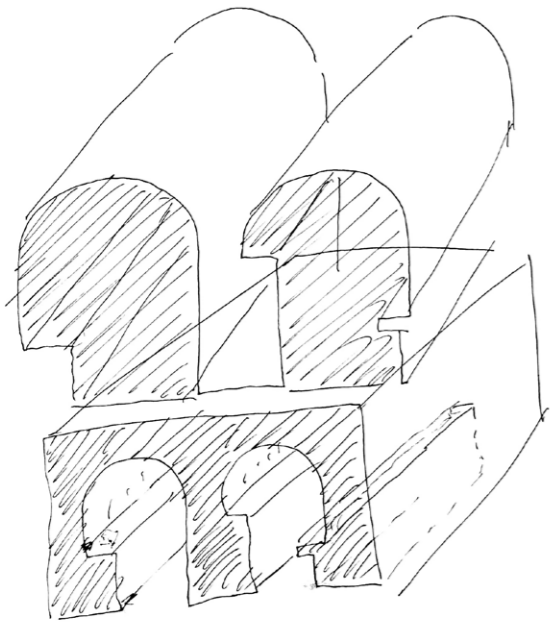

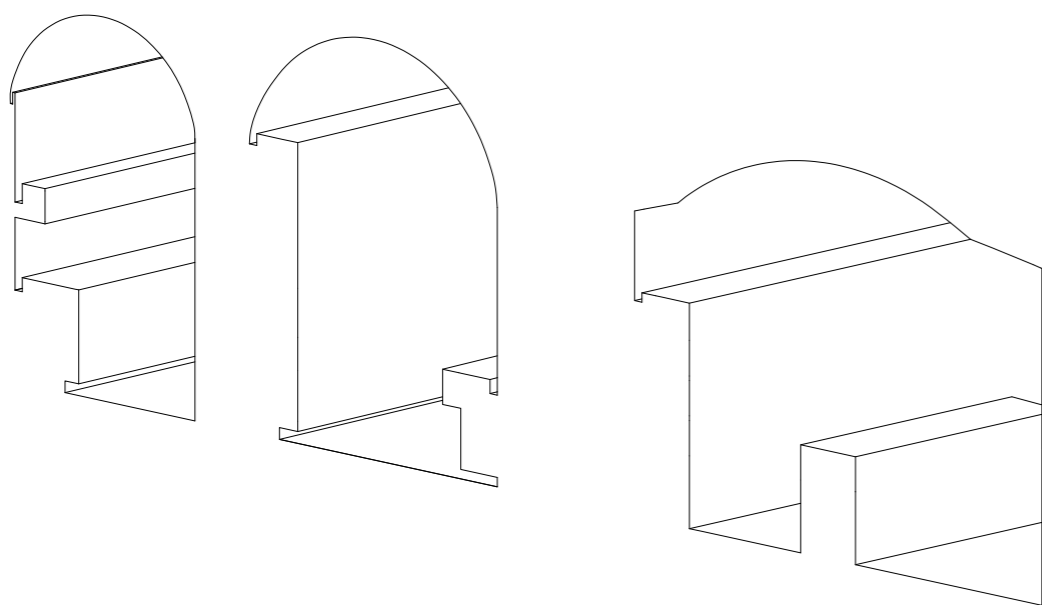



Lo spazio commerciale oggetto dell'intervento viene ricavato scavando il volume originariamente pensato come pieno e per sottrazione rimangono gli espositori e i canali per illuminare gli spazi mediante una luce continua e indiretta. I materiali usati sono: vetro extra-chiaro, legno rivestito dello stesso colore chiaro delle pareti, specchi per creare lunghezze continue, finiture materiche delle pareti studiate su misura per il cliente. Le pareti portanti sono rivestite da un cartongesso integrato perfettamente con i mobili in modo da creare un arredo monolitico e continuo. I corpi illuminanti e i profili di diffusione di aria calda e fredda saranno parte integrante dell'arredo così come i colori sobri delle pareti e degli arredi vogliono mettere più possibile al centro dell'attenzione i gioielli.

The commercial space, the focus of the work, is created by excavating the area, which was originally thought to be filled. This left the expositors and the canals to light the spaces through a continuous and indirect light. The materials used are: extra-clear, glass, wood covered in a light colored material that matches the walls, mirrors to create a continuous sense of length, material finishings on the walls made to the specifications of the client. The supporting walls are refinished in drywalling which is perfectly integrated with the furniture so as to create a mono-ambient with continuity. The lighting system and heating/air conditioning unit are integrated into the interior design and, just as the sober wall colorings and furnishings, are intended to place the jewelry as the central focus.

andrea mercati architetto
corso v. emanuele 50
06012 città di castello pg
m 0039 347 6643483
email@andreamercati.com
via lorenzo bardelli 1
50139 firenze
www.andreamercati.com